

CS750™ Hanging Scales

Medium Duty Digital Hanging Scale for Light Industrial Applications



Durable Hanging Scale Offers Comprehensive Industry Features & Superior Battery Life.

Available in capacities ranging from 100lb (50kg) to 1,000lb (500kg), including NTEP certified models, the durable CS750™ Crane Scale boasts an impressive 800 hours of continuous battery life (5,000 hours in stand-by mode), minimizing down time due to battery charging or replacement. The unit can be ordered with or without Fully Integrated RFX™ Wireless Weighing Technology and comes standard with an infrared remote control, Crosby eye hook and bottom swivel hook.

The large LCD display with automatic backlight provides easy-to-read weight readings, and a comprehensive set of keypad controls, including Tare and Accum/Total, make CS750™ Crane Scales the go-to solution for light industrial applications. All crane unit electronics are shock-mounted in a weatherproof case and provide maximum protection against moisture, dust and rough usage.

Intercomp
advanced weighing technology... by any measure

CS750™ Hanging Scales

- 100lb (50kg) to 1,000lb (500kg) Capacities
- Accuracy of $\pm 0.1\%$ of Reading
- NTEP Certified Models Available
- Large, Easy-to-Read, LCD Display
- Features Automatic Backlight, On/Off, Zero, lb/kg, Tare & Accum/Total
- Commercially Available, D-Cell Batteries (not included)
Last for up to 800 Hours of Continuous Use, 5,000 Hours in Stand-By Mode
- Available With or Without RFX™ Wireless Weighing Technology

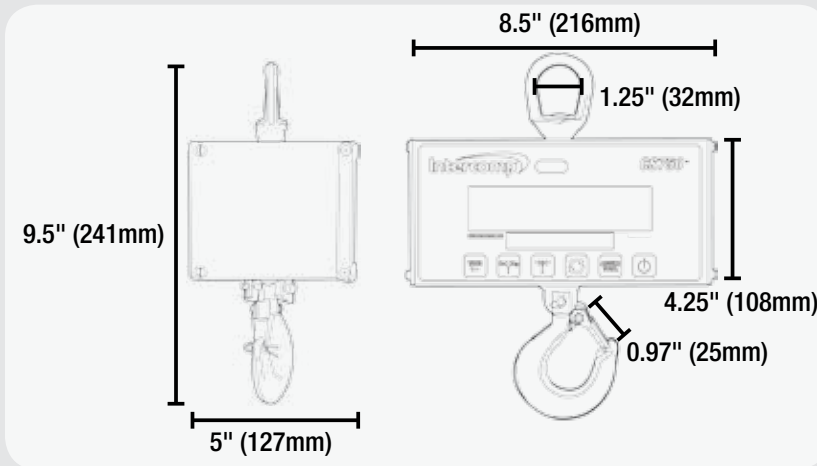

Includes:

- Infrared Remote Control
- Crosby Eye Hook
- Bottom Swivel Hook

Capacity	Graduation
100lb (50kg)	.05lb (.02kg)
300lb (150kg)*	0.1lb (.05kg)
500lb (250kg)*	0.2lb (0.1kg)
1,000lb (500kg)*	0.5lb (0.2kg)

*NTEP Certified Models

Options & Accessories

- RS232 Serial Output & Direct Power Connector
- External Battery Charger
- Direct Power Cable (100-250VAC Supply)
- Serial Output
- Thermal Printer

PERFORMANCE

Accuracy: $\pm 0.1\%$ of Reading

CONTROLS

General: Tare, lb/kg, Zero, Mode, Accum/Total & On/Off
 Display: LCD
 Display Characters: 1" (25mm)

ENVIRONMENTAL

Humidity: 10 to 95%, Non-Condensing
 Temperature: -20° to 150°F (-28° to 65°C)

ELECTRICAL

Battery: 4 x D-size Alkaline
 Battery Life: 800 Hours (5,000 Hours in Stand-By Mode)

info@intercompcompany.com

Worldwide: +1 763-476-2531

Toll Free: 800-328-3336



intercompcompany.com

Specifications subject to change without notice.

CE ISO 9001:2008 Registered



Printed in the U.S.A.

700728